

ILERSAC VBF ROBOSONIC

Automatic fluidisation bagging machine in valve bags, with enclosure and multiple filling points fed by a single robotic arm.

Output: Up to 600 bags per hour
Type of product: Powder and small granules
Level of automation: Automatic



BENEFITS

THE ILERSAC VBF ROBOSONIC AUTOMATIC FLUIDISATION BAGGING MACHINE OFFERS...

- Total automation of the bagging process
- High degree of autonomy
- Flexible production
- Optimised bagging of powder products
- Consistently heterogeneous mixtures
- Optimised space
- Dust-free work environment
- Product hygiene
- Adaptability to high hygiene standards
- Easy cleaning

APPLICATIONS

- Food: flour, starches, baking additives, sugar.
- Chemical and petrochemical: PVC, fine chemical products.
- Construction and mining: mortars, cements, general minerals.

TECHNICAL SPECIFICATIONS

POWER SUPPLY:

VOLTAGE: 380 III N+T 50 Hz

CONTROL VOLTAGE: 24V

POWER: 18 kW

PNEUMATIC SUPPLY:

PRESSURE: 6 bar

CONSUMPTION: 1,885 NL/min

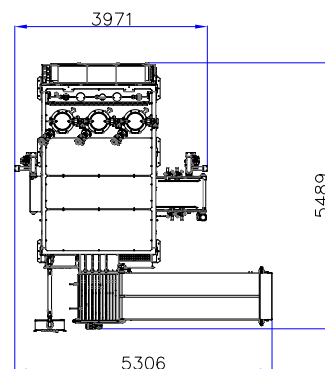
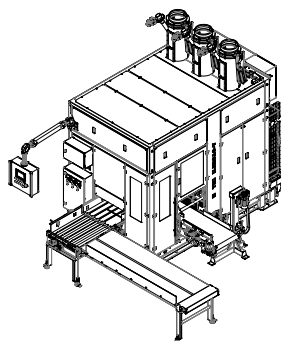
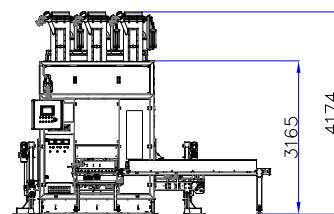
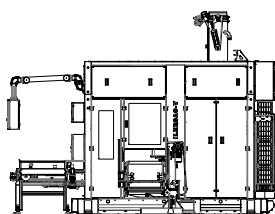

CHARACTERISTICS

- Output up to 600 bags per hour, depending on product characteristics and bag formats handled.
- The most compact bagging machine on the market in its category.
- Suitable for paper valve bags.
- Product dosing through fluidisation.
- Gross weight weighing system, including the filling spout unit in the weighing.
- Unified bag handling at one point through a robotic arm.
- Magazine for high-capacity bags with a single point of delivery for two or three filling spouts. Its configuration means that piles of bags can be restocked without stopping the machine.
- Conical valve pre-opening system, synchronised with the robot, thus guaranteeing maximum precision.
- Ultrasonic valve sealing through ILERSONIC.
- Full bag collection belt with adjustable height depending on format.
- Complete enclosure for the entire bagging machine.
- Operation through work recipes.
- Semi-automatic chamber opening systems
- Configured for easy handling without tools.

OPTIONS

- 2 or 3 filling spouts served by a single placement robot.
- ATEX versions for work in classified zones.
- Anti-corrosion versions for corrosive products.
- Anti-abrasion versions.
- Special hygienic design for the food industry.
- Automatic product collection and recovery systems.
- Multi-fluidisation for heterogeneous mixtures.
- Construction in Stainless Steel.