

ILERBOX

Automatic wrapping system with corrugated cardboard for pallet side protection. This system complements the ILERGIR automatic stretch wrapper

Production: Up to 10 pallets per hour



BENEFITS

THE ILERBOX AUTOMATIC CARDBOARD DISPENSER OFFERS...

- Maximum protection for palletised goods
- Savings in costs and storage space
- Ease of use thanks to automation
- Quick, ergonomic corrugated cardboard roll changing process
- More free space in the plant

APPLICATIONS

All types of palletised loads, in any industry. Especially suitable for industries that require superior bag protection, as in the case of chemical and phytosanitary products, which could be harmful to the environment, or of high-value products, where any return due to a broken bag could entail significant costs. It is also an excellent automated solution to replace the pallet box.

TECHNICAL SPECIFICATIONS

POWER SUPPLY:

VOLTAGE: 380 III N+T 50 Hz

CONTROL VOLTAGE: 24V

POWER: 6 kW

PNEUMATIC SUPPLY:

PRESSURE: 6 bar

CONSUMPTION: 10 NL/min

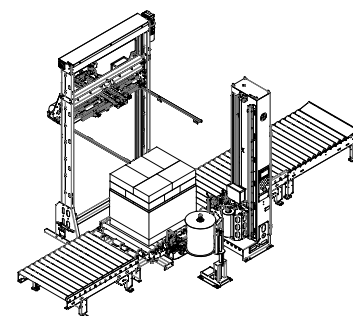
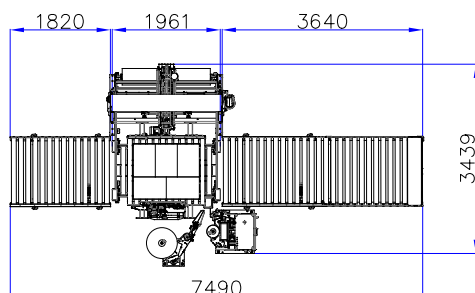
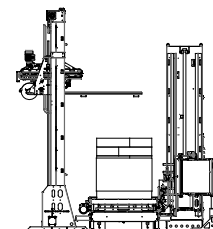
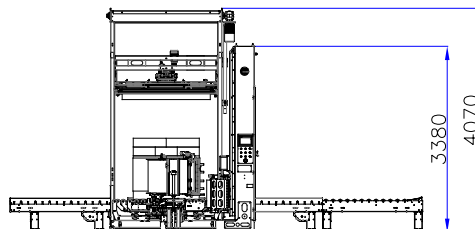

CHARACTERISTICS

- Production of up to 10 pallets per hour.
- Fully automatic cycle: no need for intervention from operator.
- The carriage for the corrugated cardboard roll is separate.
- Dispensing of cardboard up to 600 mm wide on a 500 mm diameter roll.
- Binding with corrugated cardboard fully integrated into the stretch wrapping process: no need to stop, change the roll or apply glue.
- Cutting with blade.
- Module fully built into the ILERGIR stretch wrapping machine, without taking up extra space in the plant.

OPCIONES

- Motorised mechanism to move the cardboard roll up and down to protect the whole of the pallet.
- Anti-corrosion versions for corrosive products.
- ATEX versions for work in Classified Zones.