

ILERBOX

Automatic wrapping system with corrugated cardboard to protect the sides of the pallets.

This system complements the ILERGIR model automatic stretch wrapper.

Output: Up to 10 pallets per hour



BENEFITS

THE ILERBOX AUTOMATIC CARDBOARD DISPENSER OFFERS...

- Maximum protection for palletised goods
- Savings in costs and storage space
- Ease of use thanks to automation
- Quick, ergonomic corrugated cardboard roll changing process
- More free space in the plant

APPLICATIONS

- All types of palletised loads, in any industry.
- Especially suitable for industries that require superior bag protection, as in the case of chemical and phytosanitary products, which could be harmful to the environment, or of high-value products, where any return due to a broken bag could entail significant costs.
- It is also an excellent automated solution to replace the pallet box.

TECHNICAL SPECIFICATIONS

POWER SUPPLY:

VOLTAGE: 380 III N+T 50 Hz

CONTROL VOLTAGE: 24V

POWER: 6 kW

PNEUMATIC SUPPLY:

PRESSURE: 6 bar

CONSUMPTION: 10 NL/min.

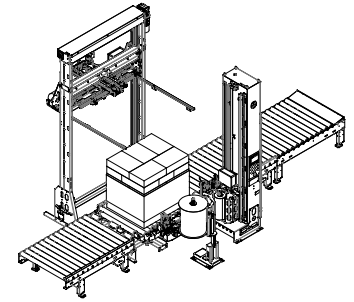
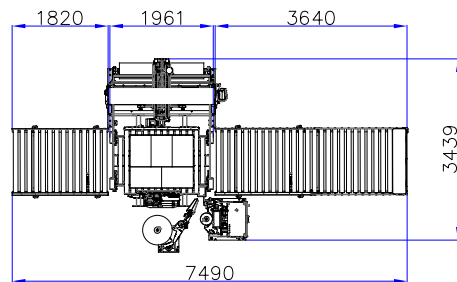
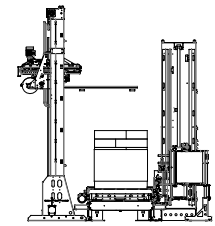
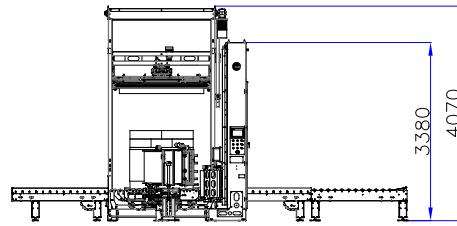

CHARACTERISTICS

- Output of up to 10 pallets per hour.
- Fully automatic cycle: no need for intervention from operator.
- The carriage for the corrugated cardboard roll is separate.
- Dispensing of cardboard up to 600 mm wide on a 500 mm diameter roll.
- Binding with corrugated cardboard fully integrated into the stretch wrapping process: no need to stop, change the roll or apply glue.
- Cutting with blade.
- Module fully built into the ILERGIR stretch wrapping machine, without taking up extra space in the plant.

OPTIONS

- Motorised mechanism to move the cardboard roll up and down to protect the whole of the pallet.
- Anti-corrosion versions for corrosive products.
- ATEX versions for work in Classified Zones.